INSTRUCTIONS FOR MODEL SG3882 SINGLE STAGE, HIGH FLOW REGULATORS

THIS BOOKLET CONTAINS PROPRIETARY INFORMATION OF
ADVANCED SPECIALTY GAS EQUIPMENT CORP. AND IS PROVIDED
TO THE PURCHASER SOLELY FOR USE IN CONJUNCTION WITH
MODEL SG3882 REGULATORS.



IMPORTANT

These instructions are for experienced operators who know the general principles and safety precautions to be observed in handling specialty gases and operating pressure regulation equipment. If you are not certain you fully understand the safety precautions for handling gases, we urge you to obtain and read the Material Safety Data Sheet (MSDS) for each gas being used.

Do not permit untrained persons to install, operate, or maintain this regulator. Do not attempt to install or operate this regulator until you have read and fully understand these instructions. If you do not fully understand these instructions, contact your Advanced Specialty Gas Equipment Distributor.

Be sure this information reaches the operator. Your supplier has extra copies.



This page has been left blank intentionally

SAFETY PRECAUTIONS

Protect yourself and others. Read and understand the following instructions before attempting to use these regulators. Failure to understand and follow these instructions could result in serious personal injury and/or damage to equipment.

- Know and understand the physical and chemical properties of the gas being used.
- Observe general precautions for the use of gases.
- Observe safety precautions for the gas being used.
- Read and follow precautions on cylinder labels.
- Never use these regulators with gases not compatible with the materials of construction. The use of gases not compatible with the materials of construction may cause damage to equipment or injury to personnel.
- If flammable gases are used with these regulators, do not locate the regulators near open flames or any other source of ignition.
- If toxic or flammable gases are used with these regulators, emergency equipment applicable to the gases in use should be available in the operating area.
- Many gases can cause asphyxiation by displacing oxygen in the atmosphere. Make certain the area where regulators are operated is well ventilated. Provide a device to warn personnel of oxygen depletion in the work area.
- Do not release toxic or flammable gases in the vicinity of personnel. Use this equipment only in well ventilated areas. Vent gases to the outside atmosphere, and in an area away from personnel. Be sure that venting and disposal methods are in accordance with Federal, State and local requirements. Locate and construct vent lines to prevent condensation or gas accumulation. Be sure the vent outlet cannot be obstructed by rain, snow, ice, insects, birds, etc. Do not interconnect vent lines; if more than one vent is needed, use separate lines.
- Relief devices should be installed and properly vented in all gas handling systems to protect against regulator failure and overpressurization.
- Never use oil or grease on these regulators. Oil and grease are easily ignited and may combine violently with some gases under pressure.
- Never connect a regulator to a supply source having a pressure greater than the maximum rated pressure of the regulator. Refer to Product Specifications (page 13) for maximum inlet pressures.

MANUFACTURER STATEMENT

The information contained in this instruction booklet has been compiled by Advanced Specialty Gas Equipment Corp., (the Company), from what it believes are authoritative sources and is offered solely as a convenience to its customers. While the Company believes that this information is accurate and factual as of the date printed, the information including design specifications is subject to change without prior notice.

DESCRIPTION

The Model SG3882 is a piston-type regulator designed for use with noncorrosive gases in applications where high flow rates are required. Typical uses include manifold or trailer applications.

A pressure relief valve installed on the Model SG3882 protects the regulator from overpressurization.

OPTIONAL EQUIPMENT

Panel Mounting Ring (PM3801) – A special panel mounting ring permits the regulator to be mounted on a panel (Fig. 1, see pg. 10).

INSTALLATION

WARNING: Before attempting to install and operate these regulators, read and fully understand the safety precautions on page 3 in this booklet. Failure to follow the safety precautions may result in serious personal injury and/or damage to equipment.

1. Inspect the regulator for physical damage or contamination. Do not connect the regulator if you detect oil, grease or damaged parts. If contaminated or damaged contact your Advanced Specialty Gas Equipment Distributor to have the regulator properly cleaned or repaired (see "Repairs").

Note: Make sure that the components and materials used with the gas handling system are compatible with the gas and have the proper pressure rating.

2. Close the regulator by turning the pressure adjusting knob counterclockwise until it reaches the stop. Do not turn the adjustment knob past the stop. Damage to the regulator could result.
3. The regulator may be supported by system piping or mounted on a panel. For panel mounting, install regulator with the optional panel mounting ring.
4. Ensure that inlet and outlet process lines are at atmospheric pressure before connecting regulator. Connect regulator to process lines. Use Teflon[®] tape on pipe threads to prevent galling.

Note: The use of joint compounds, pastes, or lubricants other than Teflon[®] tape should be avoided since they may contaminate the regulator and process gauge.

WARNING: If the regulator is to be used with hazardous gases, connect outlet of pressure relief valve to a safe disposal area.

LEAK TESTING AND PURGING

1. If it is nonhazardous, use the process gas to leak test and purge the regulator and gas delivery system.
If the process gas is hazardous (flammable and/or toxic) use clean dry nitrogen as a purge gas to leak test and purge the regulator and gas delivery system.
2. Isolate downstream side of gas delivery system by closing process isolation valve.
3. Stand to one side of the regulator and slowly introduce the purge gas into the regulator. Check inlet gauge for pressure into the regulator.
4. Open the regulator by turning the pressure adjusting knob clockwise until the desired pressure is indicated on the outlet gauge.
5. Leak check all connections with either a soap solution, such as Snoop[®] or a gas leak detector. If a leak is detected, vent system to atmospheric pressure and repair. Do not repair any leaks while system is under pressure.

Note: These regulators do not vent downstream system pressure when the pressure adjusting knob is turned counterclockwise to reduce delivery pressure. For applications where atmospheric constituents could contaminate your gas system, install a vent valve on the downstream system to vent pressure. Connect outlet of vent valve to a safe disposal area.

6. Purge entire system of air if the process gas is hazardous or sensitive to atmospheric contaminants.
7. Vent system to atmospheric pressure. Close system vent valve. Close regulator by turning pressure adjusting knob counterclockwise.

OPERATION

WARNING: Never operate a regulator under any circumstances if it is leaking or otherwise malfunctioning. DO NOT repair any leaks while system is under pressure. Damage to equipment and/or injury to personnel may result.

1. Close the regulator by turning the pressure adjusting knob counterclockwise until it reaches the stop. Do not turn the adjustment knob past the stop. Damage to the regulator could result.
2. Ensure that any purge and system vent valves are closed.
3. Slowly open supply valve to admit process gas to regulator.
4. Turn regulator pressure adjusting knob clockwise until desired delivery pressure is indicated on the outlet gauge.

Note: Do not exceed maximum working pressure of downstream system components.

SHUTDOWN

1. If regulator is not to be removed from service, close process supply valve. Always keep supply valve closed whenever the system is not in use.
2. Close regulator by turning pressure adjusting knob counterclockwise until it reaches the stop. This will prevent a sudden pressure surge from damaging downstream components when gas flow is restarted.

REMOVAL FROM SERVICE

1. Close process supply valve. Always keep supply valve closed whenever system is not in use.

WARNING: Hazardous gases must be discharged into a safety vent. Be sure to use a venting procedure that is environmentally acceptable and complies with Federal, State and local requirements.

2. Vent the system until both pressure gauges read zero psig. If regulator was used with a hazardous gas, purge the regulator and entire system with clean dry nitrogen gas. Continue purging until the hazardous gas level in the system is below the TLV for the gas.
3. After purging and/or venting is complete, close regulator by turning pressure adjusting knob counterclockwise until it reaches the stop.
4. Remove regulator from supply line.

PERFORMANCE CHARACTERISTICS

Normal Operating Characteristics

- As flow is increased through a regulator, delivery pressure will drop (droop).
- As the inlet pressure to the regulator changes, the delivery pressure will vary (supply pressure effect). This effect is minimal in a two-stage regulator and more pronounced in a single-stage regulator.
- The difference in delivery pressure between flow and no-flow conditions is displayed on a regulator flow curve.

Abnormal Operating Characteristics

- Insufficient sealing of the valve seat assembly caused by foreign materials or wear will allow pressure to continue building in the low pressure chamber. The pressure rise may cease, or it may continue as a leak. If the latter occurs, the regulator must not be used until repaired.

CARE AND MAINTENANCE

Periodic checking of your regulator is essential to continued safe and satisfactory operation. How often you inspect will depend on the usage and type of gas.

It is recommended that regulators in non-corrosive gas service be inspected on at least a monthly basis and those in corrosive service at least once a week. We recommend that most regulators be serviced annually; those used in corrosive service may need servicing every six months. Generally, the valve seat assembly and diaphragm assembly will be replaced, especially if the regulator is used in corrosive gas service. It is even possible that some regulators must be scrapped if badly corroded.

Regulator Checking Procedure

1. Inspect gauges. The gauge(s) should read zero when all pressure has been relieved from the system.
2. Turn the pressure adjusting knob counterclockwise until it reaches the stop. Isolate downstream side of gas delivery system by closing instrument or process isolation valve.
3. Leave the regulator in the pressurized state for five or ten minutes. The pressure gauge should not register any pressure increase. A pressure increase indicates internal valve assembly leakage. If a pressure increase is indicated, the regulator must be repaired to prevent damage to downstream equipment.
4. Next, turn the pressure adjusting knob clockwise and set a nominal delivery pressure. If you are unable to attain the normal delivery pressure setting, faulty operation is indicated. This condition may be attributed to blockage caused by a stuck valve seat within the regulator. If the set delivery pressure continues to rise above the set point, the regulator valve seat may be worn. This condition is called "creep"; and a regulator exhibiting this condition should be sent for repair.
5. Close the supply valve and isolate the regulator from the downstream system by closing instrument or process isolation valve and note the pressure on both the high and low pressure gauges. After five or ten minutes a drop in pressure on the gauge indicates a leak in the system. The leak may be at the connections, any threaded port, through the diaphragm or pressure gauge. If the leak is at the connections, relieve all pressure from the regulator and then tighten. If the leak is elsewhere, the regulator must be repaired.

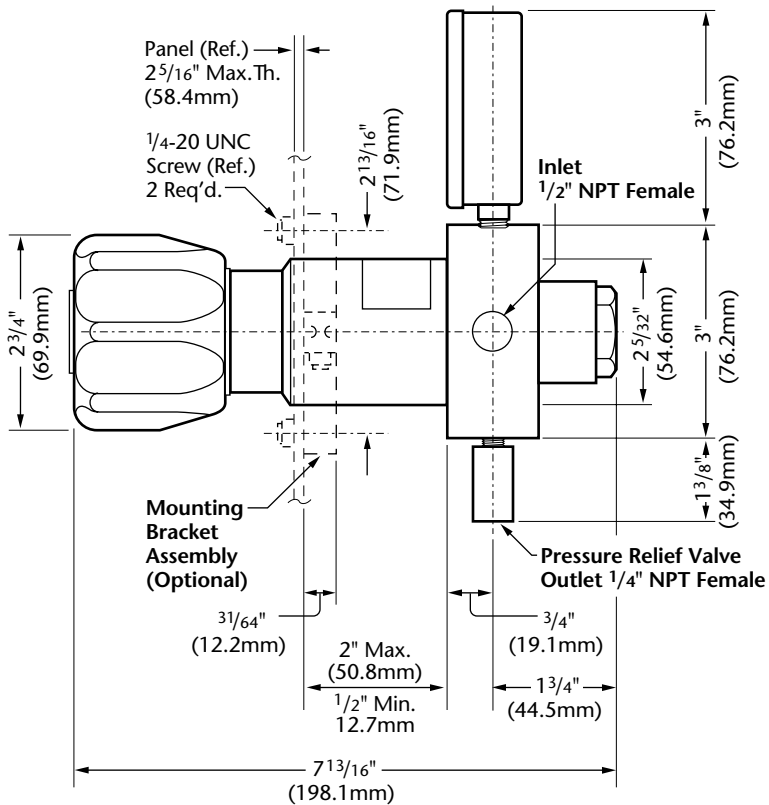

RIGHT SIDE VIEW

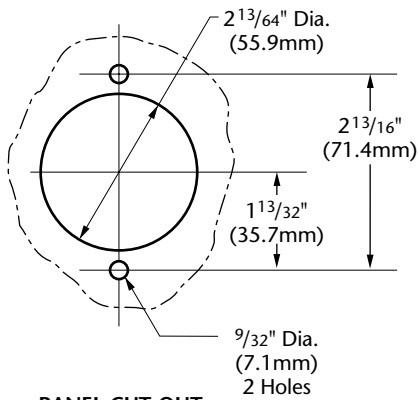

PANEL CUT-OUT

Figure 1 – Model SG3882 Regulator

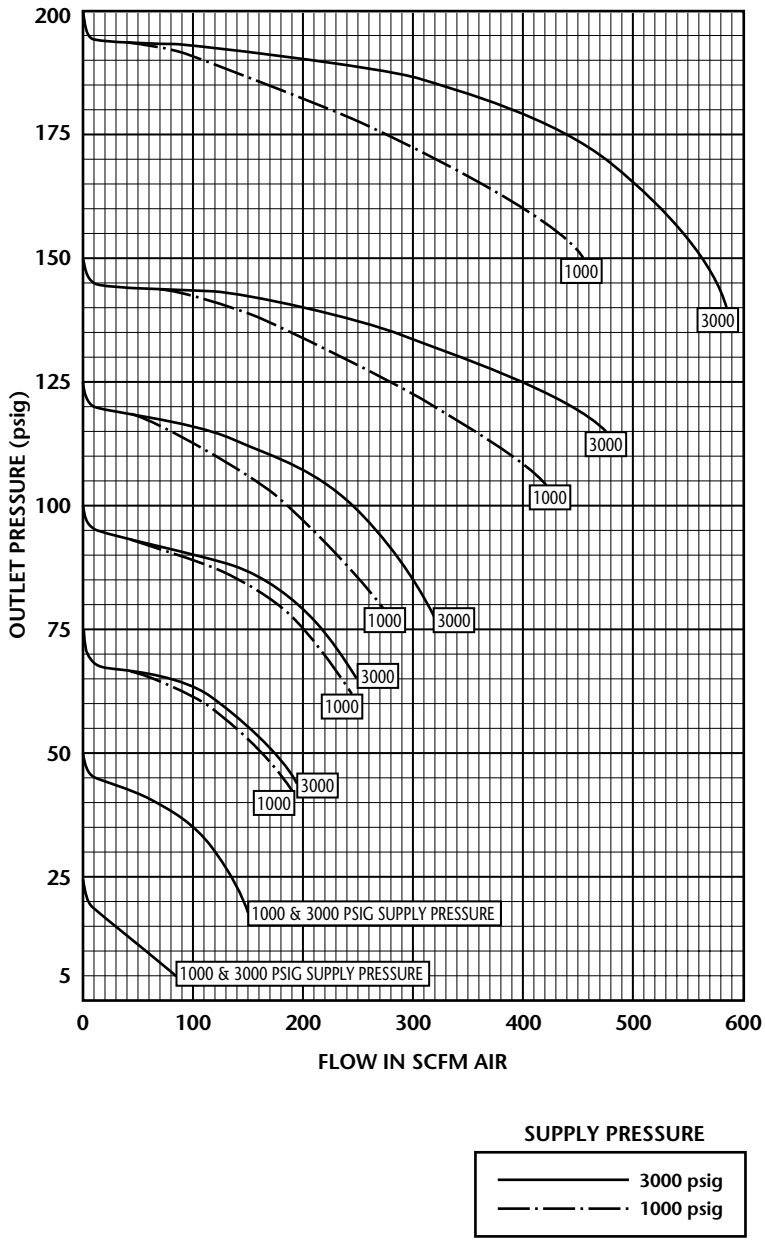

Figure 2 – Typical Performance
Model SG3882 Regulator

REPAIRS

If a regulator leaks or malfunctions, take it out of service immediately. Do not attempt to repair these regulators. Repairs should be made by Advanced Specialty Gas Equipment Corp. who have the special tools, test equipment and trained personnel required to make a safe repair. Contact your Advanced Specialty Gas Equipment Distributor to arrange for repair.

Warranty Repairs are only available through Advanced Specialty Gas Equipment Corp., and will be performed at no charge for parts and labor. For information on warranty, see the last page of this instruction booklet.

Non-Warranty Repairs are available through your distributor. Upon receipt at the factory, the regulator will be inspected and you will be contacted by your distributor with a repair cost estimate. No item will be repaired until approval is received. There will be an evaluation charge assessed for equipment not repaired.

SPECIFICATIONS

Maximum Inlet Pressure	3000 psig
Inlet Pressure Gauge	0–4000 psig
Delivery Pressure Range	20–350 psig
Delivery Pressure Gauge	0–400 psig
Relief Valve Pressure Setting	400 psig
Gauge Size	2 ½ in. dial
Operating Temperature Range	0°F to +165°F
Flow Coefficient	$C_V = 1.7$
Flow Capacity	See Figure 2
Supply Pressure Effect	0.5 psi per 100 psi
Inlet and Outlet Connections	½ in. NPT female
Weight (approx.)	7 lbs.

MATERIALS OF CONSTRUCTION

Body, Bonnet and Gauges	Brass
Internal Metal Parts Exposed to Gas	Brass & Stainless Steel
Seat	Teflon®
Seals	Viton®

WARRANTY

Advanced Specialty Gas Equipment Corp., (the Company), warrants to the initial purchaser of each regulator described herein, that such equipment will be free from defects in material and workmanship which result in breakdown or failure under normal use during a period of 12 months from date of shipment by the Company if used and maintained according to Advanced Specialty Gas Equipment written instructions. Purchaser is aware that this equipment is designed for specific applications and that using this equipment with the wrong or improperly purged gas or at the wrong pressure may damage or corrode the unit and cause personal injury. This warranty does not cover damage or malfunction due to corrosion. Purchaser must confirm that this equipment is compatible with the gas being passed through it. If there is any doubt about compatibility, consult your Advanced Specialty Gas Equipment Corp. distributor.

The Company's liability under this warranty shall be limited to the repair, or at its option, replacement or refund of the purchase price, of such equipment which proves to be defective, provided; however, that this warranty shall only apply if the purchaser (1) gives the Company written notice within ten (10) days after discovery of such defect, (2) immediately on discovery of the claimed defect, discontinues all use of such equipment, and (3) returns such equipment freight prepaid to plant of manufacture.

THERE ARE NO EXPRESS WARRANTIES OTHER THAN THOSE SPECIFIED HEREIN. NO WARRANTIES BY ADVANCED SPECIALTY GAS EQUIPMENT CORP. (OTHER THAN WARRANTY OF TITLE AS PROVIDED IN THE UNIFORM COMMERCIAL CODE) SHALL BE IMPLIED OR OTHERWISE CREATED UNDER ANY APPLICABLE LAW, INCLUDING BUT NOT LIMITED TO WARRANTY OF MERCHANTABILITY AND WARRANTY OF FITNESS FOR A PARTICULAR PURPOSE. No claim against the Company of any kind, whether as to equipment delivery or for nondelivery of equipment and whether or not based on contract, warranty, negligence, strict liability in tort or otherwise, shall be greater in amount than the purchase price of the equipment in respect of which such claim is made.

Without limiting the generality of the foregoing, Advanced Specialty Gas Equipment Corp. shall not be liable for any special, indirect, or consequential damage, such as failure of parts resulting from corrosion.

If it is determined by Advanced Specialty Gas Equipment Corp. that the equipment is to be repaired or replaced under the terms of this warranty, the cost of returning said equipment to the initial purchaser will be paid by the Company. If, however, equipment returned to the Company in connection with a claim under this warranty is found by the Company not to be defective hereunder, then such equipment will be returned to the initial purchaser, shipping charges collect, and additionally, a service charge will be paid by the purchaser to the Company to cover the cost of handling and testing such equipment.

This page has been left blank intentionally



241 Lackland Drive, Middlesex, NJ 08846
Phone: 732-271-9300 Fax: 732-271-1630 www.asge-online.com